

# eMark by Solaris

An Affordable Laser Coding System in one compact package



- **Most inexpensive** laser system for permanent marking/coding
- **Vector-quality** codes in stationary and „On the Fly” operation
- **All-type marks** like alphanumerical texts/dates/timers, serial numbers, barcodes, 2D codes and graphics
- **Complete list of options** for quick installation and simple operation
- **Easy integration** with new and existing production lines due to multiple I/O signals and field configurable beam exit direction
- **Simple local and remote system control** via USB, network and WiFi module

## Laser coding examples



Coated paper/cardboard



PVC



Plastic



Thermo sensitive label



Coated metal

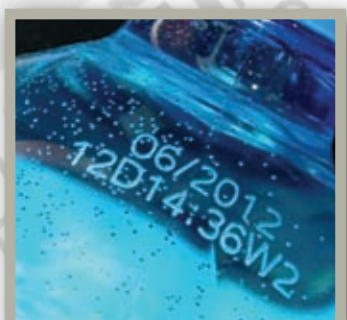

PET

# eMark by Solaris

An Affordable Laser Coding System in one compact package

## Technical Specifications

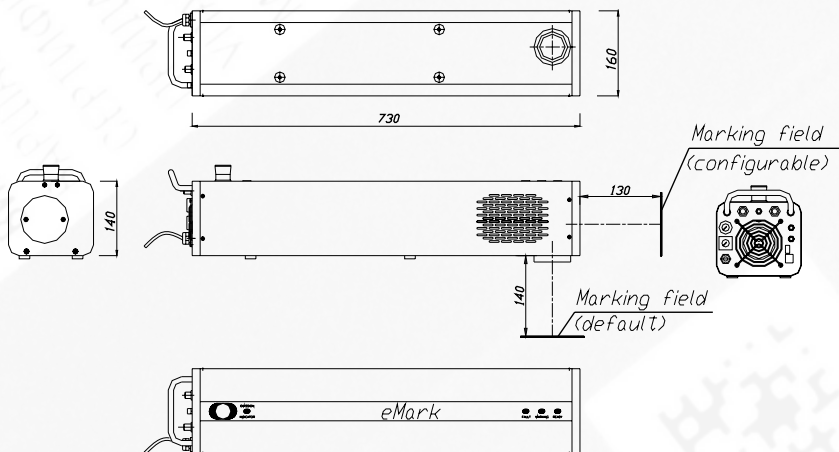

Laser type	CO <sub>2</sub>
Electrical requirements	230V 50Hz / 115V 60Hz (auto-adjustable)
Power consumption	400W
I/O signals for installation	Shaft encoder Interlock, File selection inputs Product detector input: NPN / PNP - 24V Sensor System On-line, Marking outputs
Cooling	Air, integrated
Ambient temperature	10-40°C (50-104°F); Suggested 15-30°C (59-86°F)
Humidity	up to 80%, non-condensing
Enclosure Type	IP 52 / NEMA 12
Weight	15 kg (33 lb.)
Communication	USB / Ethernet 10 Base T
Software	SolMark II job editor for Windows 9x, NT, 2000, ME, XP, Vista Multilanguage WWW site for system configuration and remote control

### DIMENSIONS



### OPTIONAL EQUIPMENT:

- Handheld terminal for local job edition
- USB industrial HUB
- Safety enclosure with product detector holder
- Rugged T-base stand for quick installation
- WiFi module
- Fumes / Dust Extractor (with Active Carbon filter)
- Shaft Encoder with mechanical holder and wheel
- Product detector
- File selection hand-switch
- External air blower for cooling in harsh environment

Specifications are subject to change without notice as products are continually improved.  and  compliant



Solaris Laser S.A.  
Wynalazek 6, 02-677 Warsaw, Poland  
Tel.: +48 22 856 89 70  
Fax: + 48 22 843 26 36  
info@solarislaser.com.pl

[www.solarislaser.com.pl](http://www.solarislaser.com.pl)



Solaris Laser S.A.  
LIA member since 1996